

2-DIGIT COUNTER/TIMER

Catalog No. NL-360,

DESCRIPTION

Two-digit counter/timer with optional internal or external thumbwheels and digital readout. Clock for timer application is generated by 110 VAC line power (60 Hz). Timer range is 0 to 9.9 sec (10 Hz) or 0 to 99 sec (1 Hz). Also has LED on A = B output.

Catalog numbers for available options:

- NL-360 (no options)
- NL-360T (with thumbwheel)
- NL-360R (with readout)
- NL-360TR (with thumbwheel and readout)

For high speed modules (0.1 ms propagation delay), add HS to catalog number (i.e., NL-360 THS).

PICTORIAL LENS. Standard lens shown.

TEST POINTS. A = B output accessible at front faceplate to facilitate signal tracing.

TERMINATION. Nickel gold-plated edge pins are used for all input-output connections.

KEY SLOTS. Prevent incorrect module replacement.

SPECIFICATIONS

Number of circuits	1
Logic type	TTL
Fan-in	
Logic 1	1 unit load (1.6 mA, source)
Logic 0	1 unit load (40 microamps, sink)
Fan-out	
Logic 1	10 unit loads (16 mA, sink)
Logic 0	10 unit loads (400 microamps, source)
Propagation delay	
NL-360	0.5 ms, 950 Hz (nominal)
NL-360HS	0.1 ms, 4750 Hz (nominal)
	Modules with options are also offered at both speeds.
Logic levels	
Logic 1	0.0 to 0.8 VDC
Logic 0	2.4 to 5.0 VDC
Power requirement	+5.7 ± 0.25 VDC
Without readouts	150 mA
With readouts	450 mA
Temperature rating	0° to 85°C
With internal readout	0° to 75°C
Noise energy rejection	5 x 10 ⁻⁶ watt seconds
Mechanical keying	Between pins 13 & 15 and pins 21 & 23
Electrical interlock	Pin 21 to pin 23
Timer accuracy	+17 ms (max.) over entire range

APPLICATION NOTES

1. Contains power-on reset delay circuit; sets counter to 00, (30 ms, nominal).
2. ENABLE: Logic 0 at ENABLE inhibits CLOCK.
3. A = B OUTPUT: When counter equals number selected by thumbwheels, output will become TRUE (logic 1) and LED will

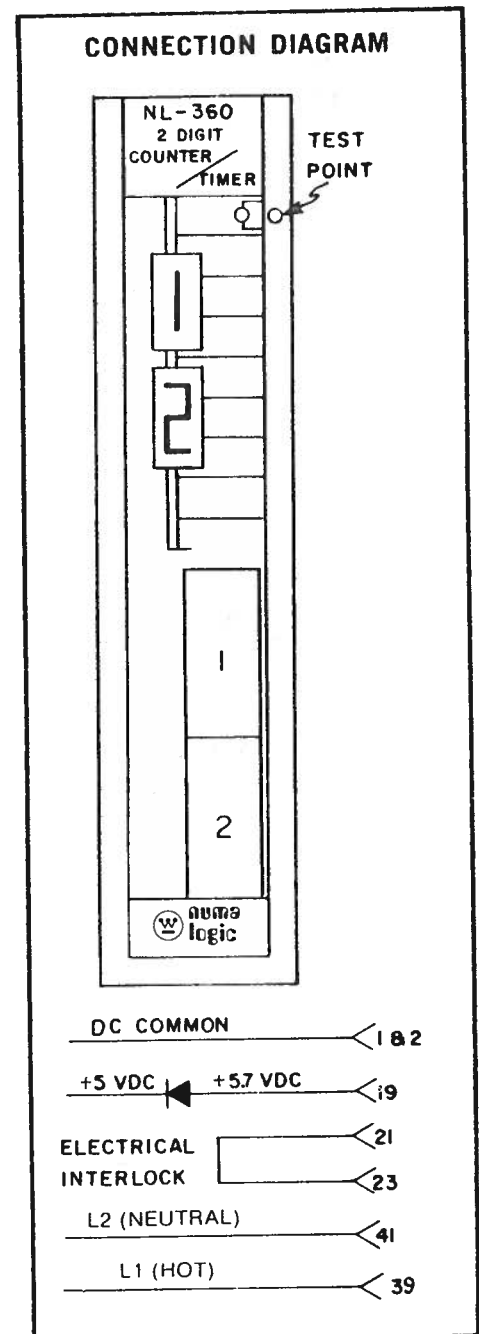
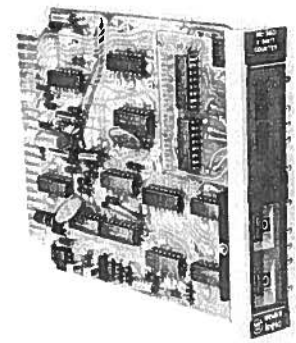

2-DIGIT COUNTER/TIMER

light.

4. RESET: Logic 1 at RESET input sets counter back to 00. RESET overrides ENABLE and CLOCK.
5. COUNTER APPLICATION: A clock pulse (1 ms long, min. for NL-360; 0.2 ms, min. for NL-360HS) at CLOCK input will cause counter to increment.
6. TIMER APPLICATION: 10 Hz and 1 Hz are generated from 110 VAC on the module. For a 0 to 99 second timer, 1 Hz must be tied to CLOCK. For a 0 to 9.9 second timer, 10 Hz must be tied to CLOCK. If using optional display and 0 to 9.9 second timer, a decimal point can be programmed on the display by jumpering pin 11 to 5.0 VDC. For other timing ranges, an external clock must be used.
7. Count will change on a clock transition from a logic 0 to a logic 1.

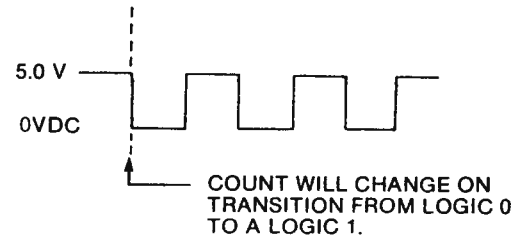

APPLICATION EXAMPLE

1. Digital Timer (0 to 9.9 sec)

Timer will stop when it reaches the thumbwheel setting

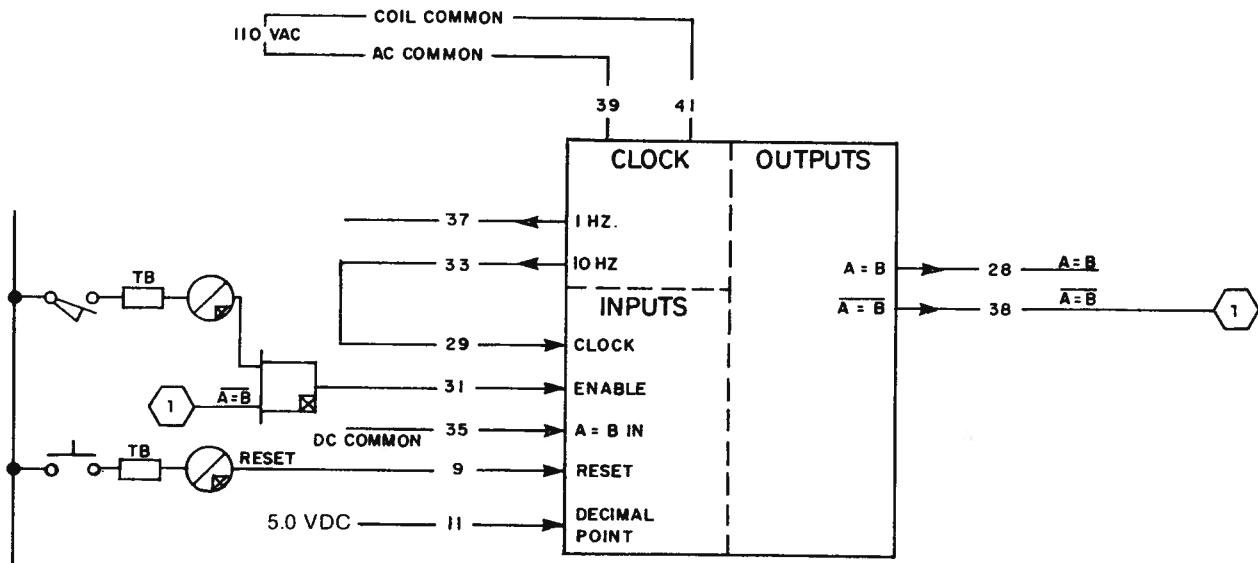

NOTE: A = B IN MUST BE TIED TO DC COMMON EXCEPT FOR CASCADE OPERATION. (SEE APPLICATION NOTE #3.)

2. Digital Timer (0 to 99 sec)

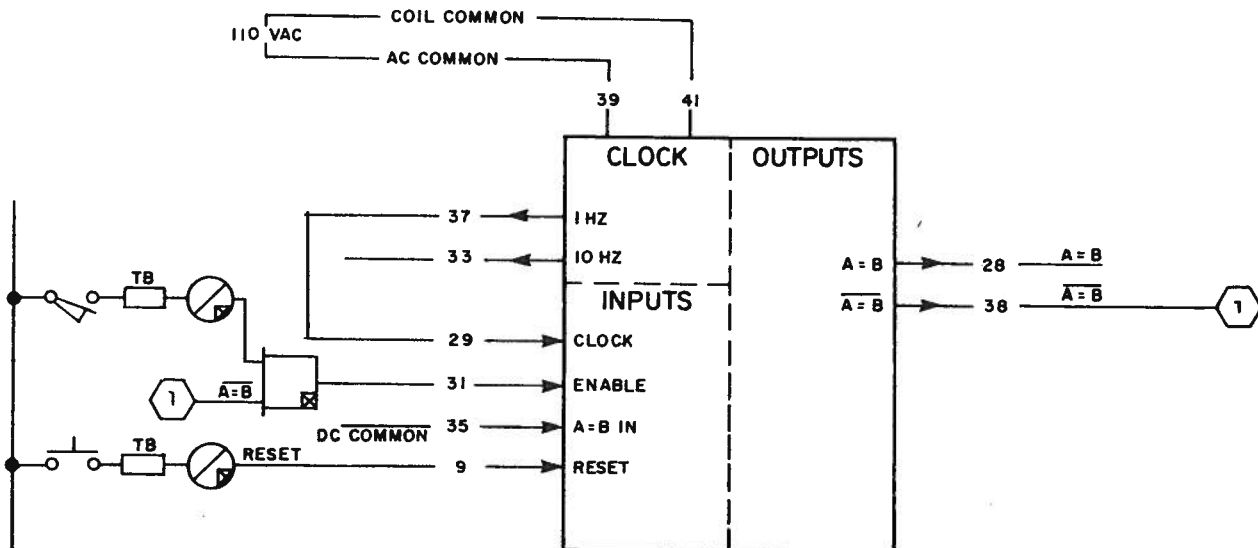

2-DIGIT COUNTER/TIMER

APPLICATION EXAMPLES

3. Digital Timer cascade operation (0 to 9999 sec)

Any number of modules may be cascaded. The module with the least significant digits must be clocked by 1 Hz or 10 Hz (timer operation), and its A = B input must be tied to pin 1. Its A = B output must be tied to the A = B input of the next module and its CARRY must be tied to the CLOCK of the next module.

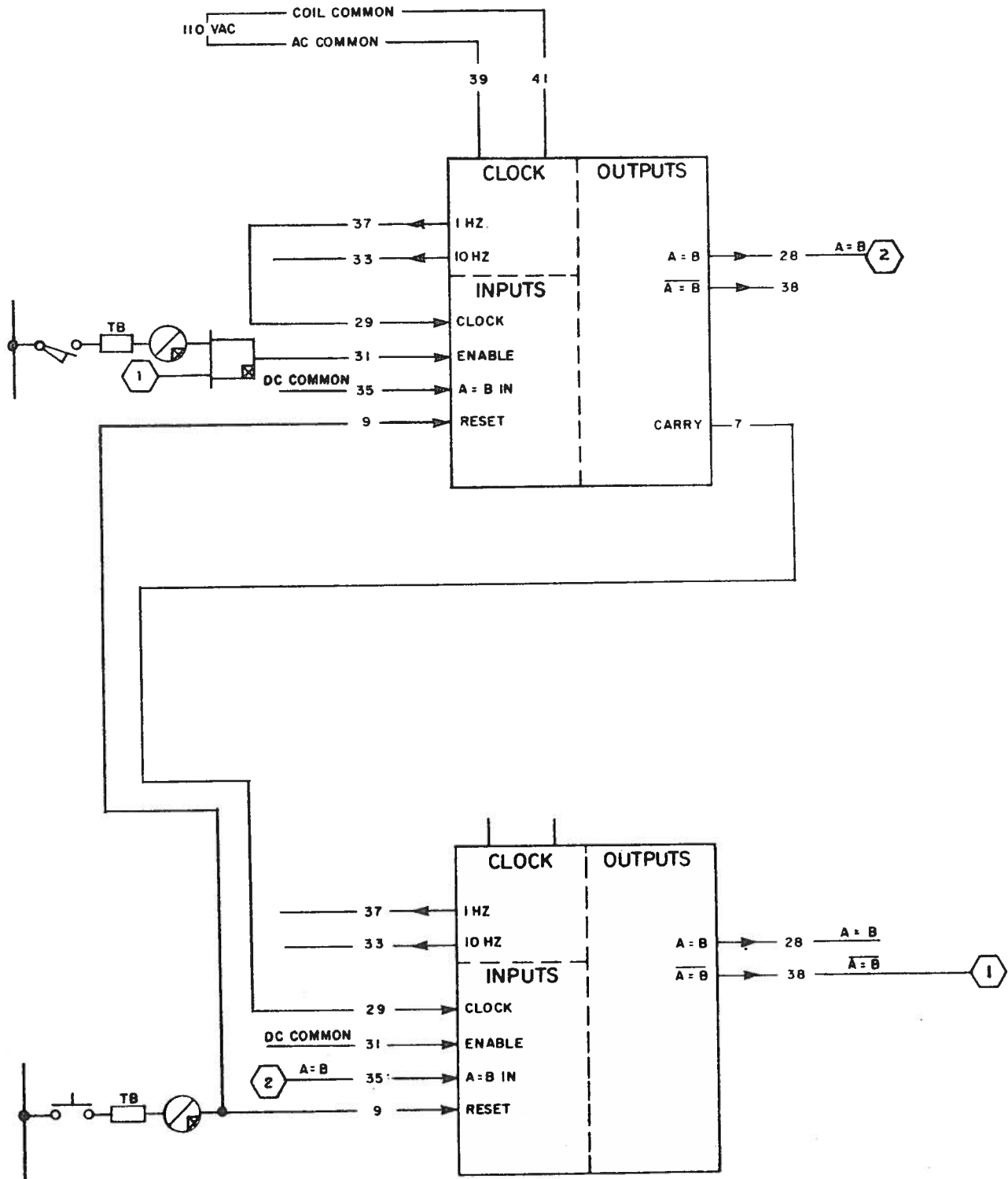

2-DIGIT COUNTER/TIMER

APPLICATION EXAMPLES

4. Digital Counter (0 to 99)

See Application Example 3 for cascading digital counters. Counter will increment each time limit switch is closed and opened. When thumbwheel setting is reached, counter will stop.

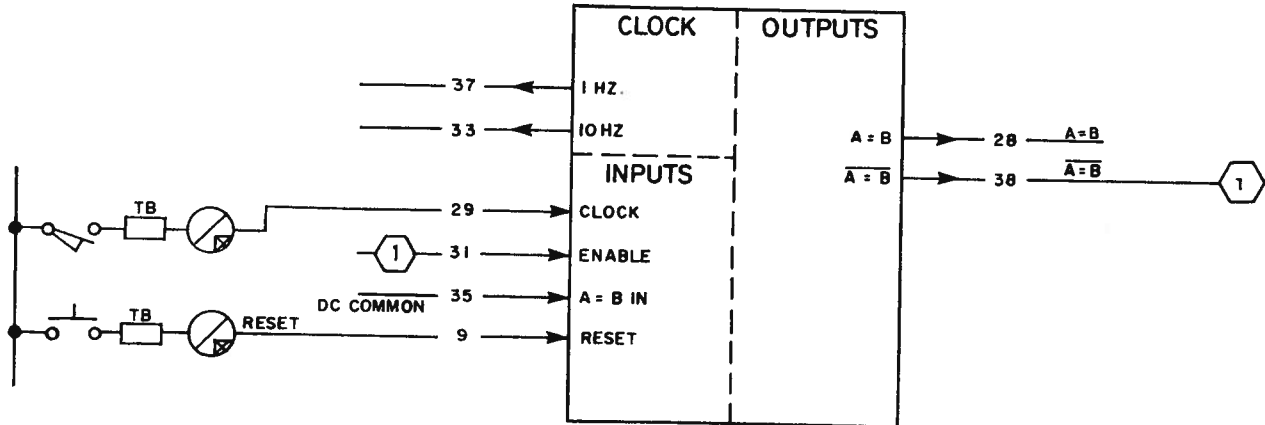

5. Digital Timer/Counter

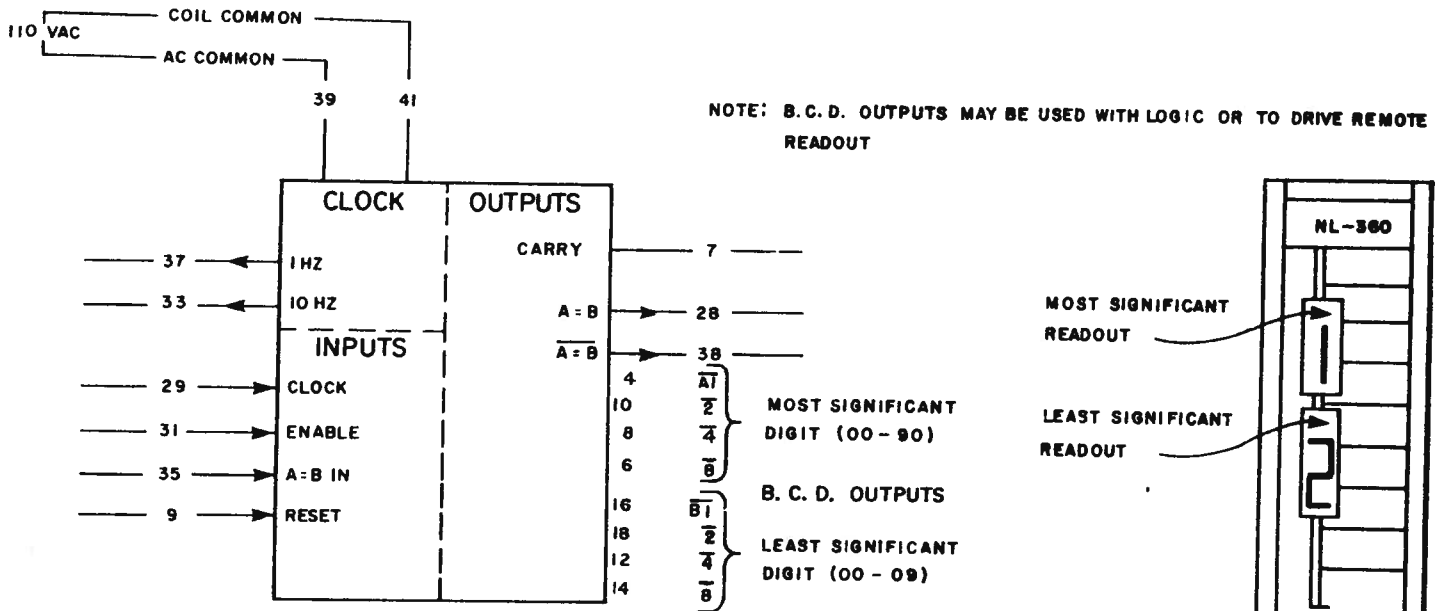

6. Remote Operation

- Maximum distance from module to remote readout and/or thumbwheel inputs is 20 feet
- Use Remote Readout, Catalog Number NLR-002
- Use Remote Thumbwheel, Catalog Number NLT-002
- Use Connector and Cable, Catalog Number NLT-005, for external thumbwheel inputs.

2-DIGIT COUNTER/TIMER

REMOTE READOUT NLR-002

Temperature range	0° to 65° C
Supply voltage	+5 ± 0.25 VDC
Supply current	508 mA all segments illuminated (2-digit) 535 mA all segments and decimal point illuminated (2-digit)
Maximum remote distance	20 feet
When decimal is required	Jumper pins J and K of digit A on NLR-002

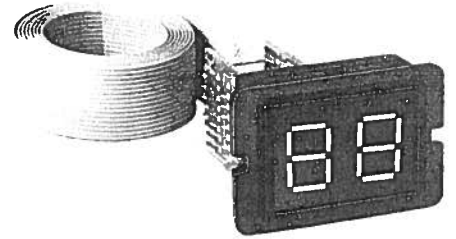

DIMENSIONS in Inches

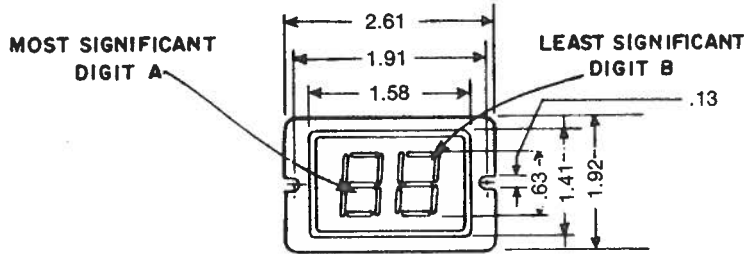

CONNECTIONS

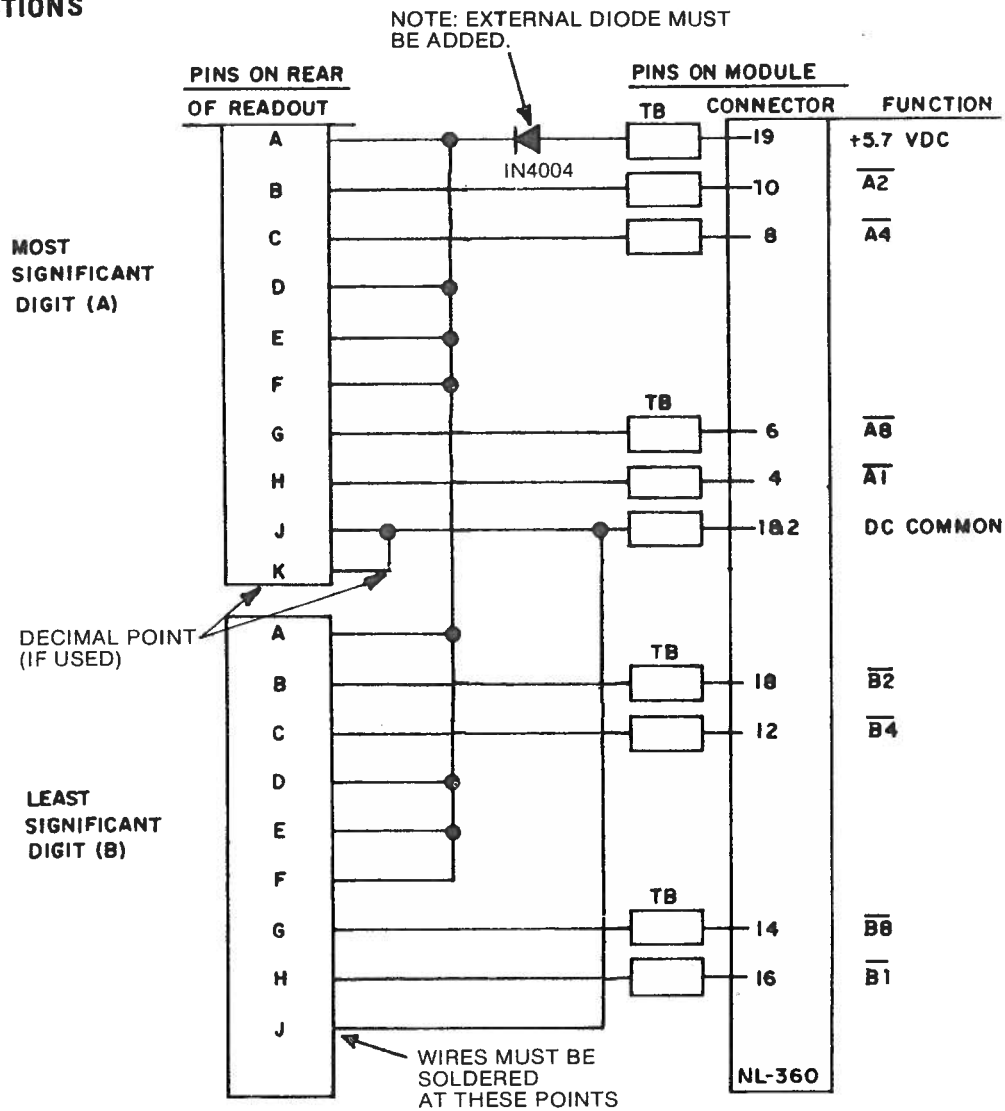

2-DIGIT COUNTER/TIMER

Remote Thumbwheels NLT-002

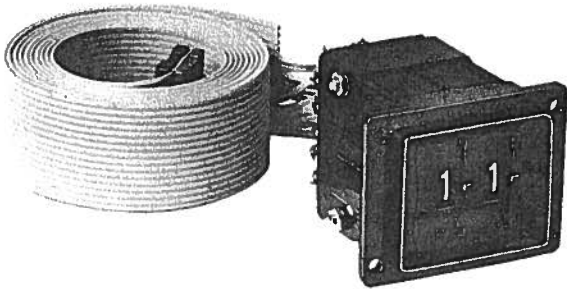

DIMENSIONS in Inches

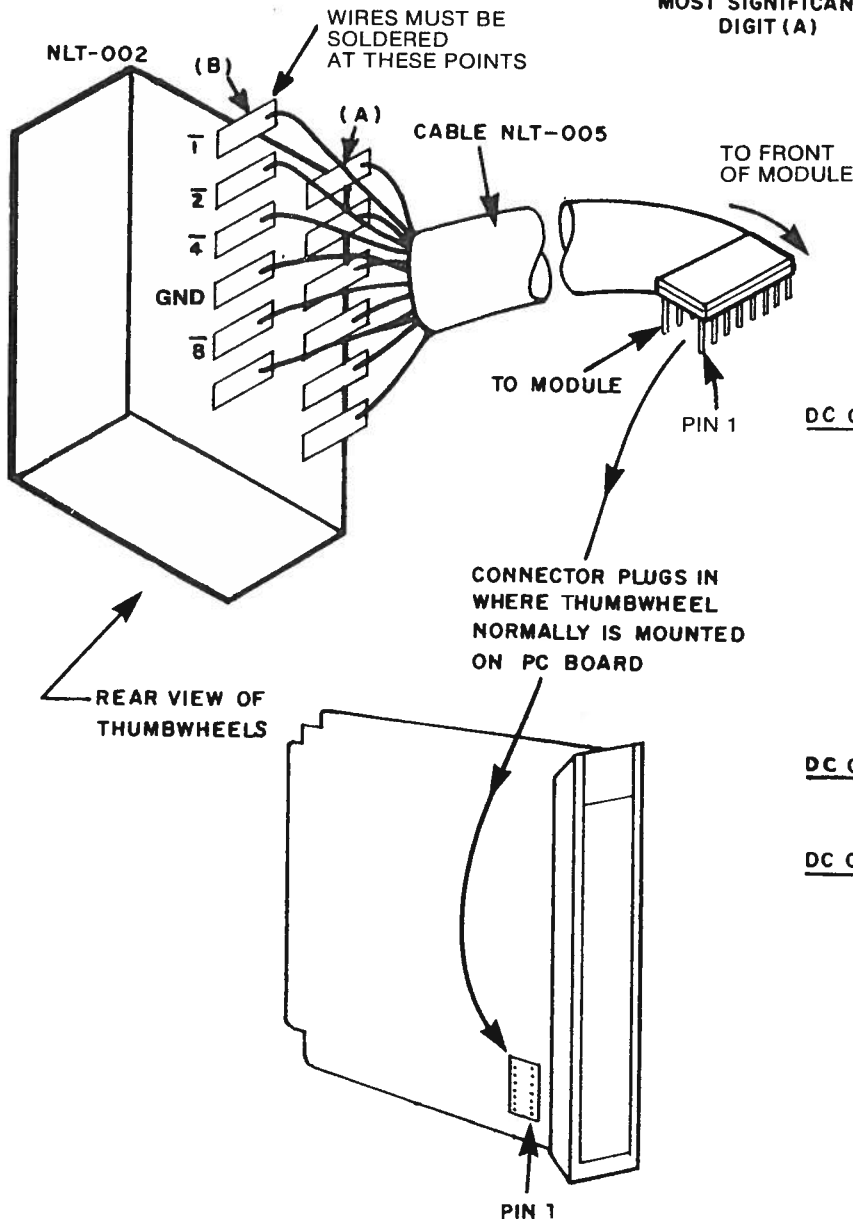
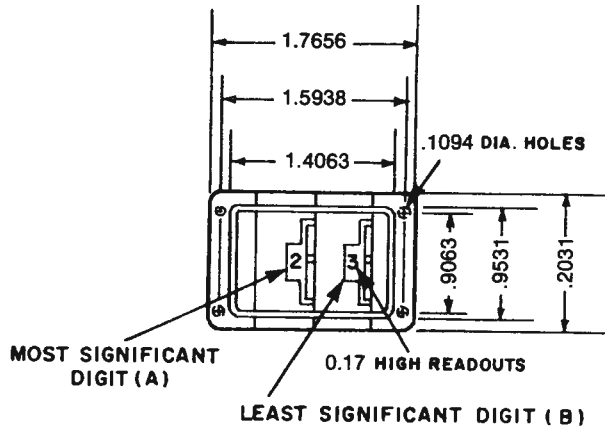

NOTE: PINS 8 AND 9 DO NOT PLUG INTO SOCKET BUT EXTEND OVER TOP EDGE

CONNECTIONS

FUNCTION	WIRE NO.	
NC	16	8
NC	15	9
DC COMMON	GND	14
NC	13	10
A2	12	6
B1	11	11
A1	10	5
B2	9	12
NC	8	4
DC COMMON	GND	7
A4	6	13
DC COMMON	GND	5
A8	4	14
B4	3	15
NC	2	1
B8	1	16

RED STRIPE
A = PREFIX MSD B = PREFIX LSD



3-DIGIT COUNTER/TIMER

Catalog No. NL-361

DESCRIPTION

Three-digit counter/timer with optional internal or external thumbwheels and digital readout. Clock for timer application is generated by 110 VAC line power (60 Hz). Timer range is 0 to 99.9 sec (10 Hz) or 0 to 999 sec (1 HZ). Also has LEDs on A=B output.

Catalog numbers for available options:

- NL-361 (No options)
- NL-361T (with thumbwheel)
- NL-361R (with readout)
- NL-361B (with buffer)
- NL-361TR (with thumbwheel and readout)
- NL-361TB (with thumbwheel and buffer)
- NL-361RB (with readout and buffer)
- NL-361TRB (with thumbwheel, readout and buffer)

For high speed modules (0.1 ms. propagation delay) add HS to catalog number (i.e. NL-361THS).

PICTORIAL LENS. Standard lens shown.

TEST POINTS. A = B output accessible at front faceplate to facilitate signal tracing.

TERMINATION. Nickel gold-plated edge pins are used for all input-output connections.

KEY SLOTS. Prevent incorrect module replacement.

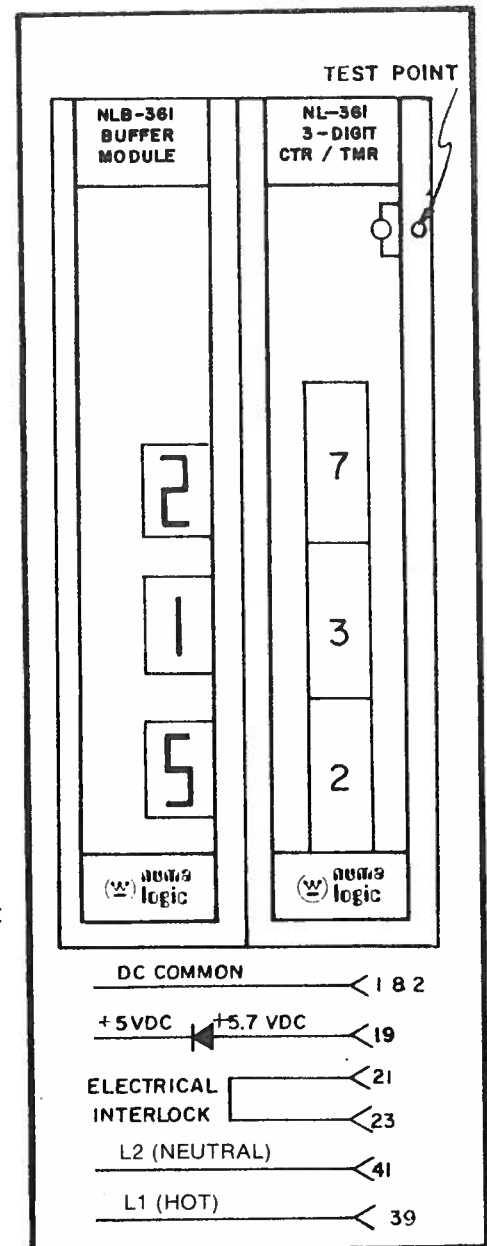
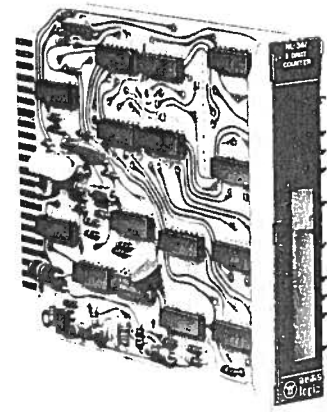

SPECIFICATIONS

Number of circuits	1
No. of rack positions	One position - NL-361, NL-361HS, NL-361T and NL-361THS. All other modules require two rack positions.
Logic type	TTL
Fan-in	
Logic 1	1 unit load (1.6 mA, source)
Logic 0	1 unit load (40 microamps, sink)
Fan-out	
Logic 1	10 unit loads (16 mA, sink)
Logic 0	10 unit loads (400 microamps, source)
Logic levels	
Logic 1	0.0 to 0.8 VDC (nominal)
Logic 0	2.4 to 5.0 VDC (nominal)
Propagation delay	
NL-361	0.5 ms, 950 Hz (nominal)
NL-361HS	0.1 ms, 4750 Hz (nominal)
	Modules with options are also offered at both speeds.
Power requirement	+5.7 ± 0.25 VDC
Without readouts	200 mA
With readouts	650 mA
Temperature rating	0° to 85°C
With internal readout	0° to 75°C
Noise energy rejection	5 x 10 ⁻⁶ watt seconds
Mechanical keying	Between pins 13 & 15 and pins 23 & 25
Electrical interlock	Pin 21 to pin 23



3-DIGIT COUNTER/TIMER

SPECIFICATIONS (CONT.)

Control signals	
CLOCK input	1 ms, min (500 Hz)
CLEAR input	1 ms, min
Timer accuracy	+17 ms (max.) over entire range

APPLICATION NOTES

1. Contains power-on reset delay circuit; sets counter to 000, (30 ms, nominal).
2. ENABLE: Logic 0 at ENABLE inhibits CLOCK.
3. A = B OUTPUT: When counter equals number selected by thumbwheels, output will become TRUE (logic 1) and LED will light.
4. RESET: Logic 1 at RESET input sets counter back to 000. RESET overrides ENABLE and CLOCK.
5. COUNTER APPLICATION: A clock pulse (1 ms long, min. for NL-361; 0.2 ms, min. for NL-361HS) at CLOCK input will cause counter to increment.

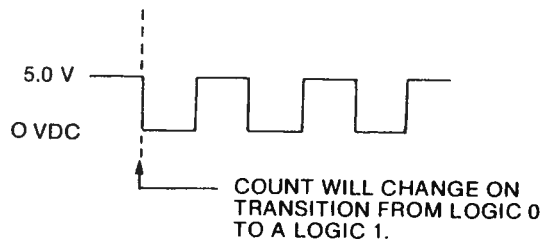

6. TIMER APPLICATION: 10 Hz and 1 Hz are generated from 110 VAC on the module. For a 0 to 999 second timer, 1 Hz must be tied to CLOCK. For a 0 to 99.9 second timer, 10 Hz must be tied to CLOCK. If using optional display and 0 to 99.9 second timer, a decimal point can be programmed on the display by jumpering pin 27 to 5.0 VDC. For other timing ranges, an external clock must be used.
7. Count will change on a clock transition from a logic 0 to a logic 1.

3-DIGIT COUNTER/TIMER

APPLICATION EXAMPLES

1. Digital Timer (0 to 99.9 Sec)

Timer will stop when it reaches the thumbwheel setting

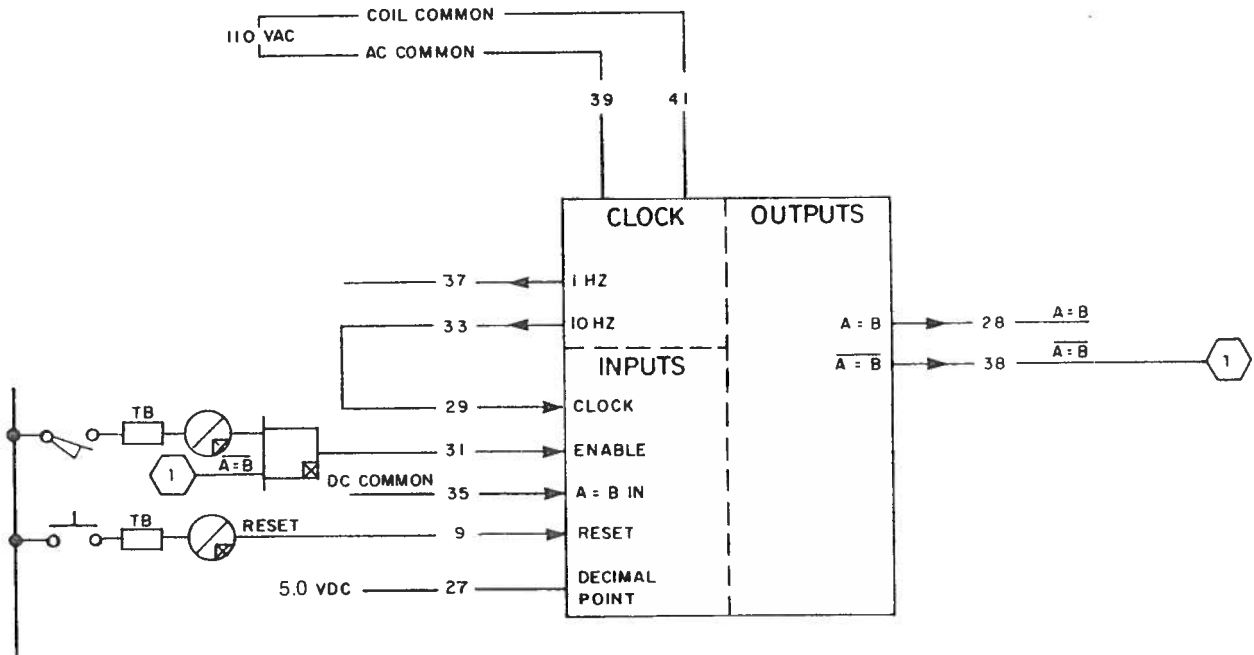

NOTE: A = B IN (PIN 35) MUST BE JUMPERED TO DC COMMON EXCEPT FOR CASCADE OPERATION

2. Digital Timer (0 to 999 Sec)

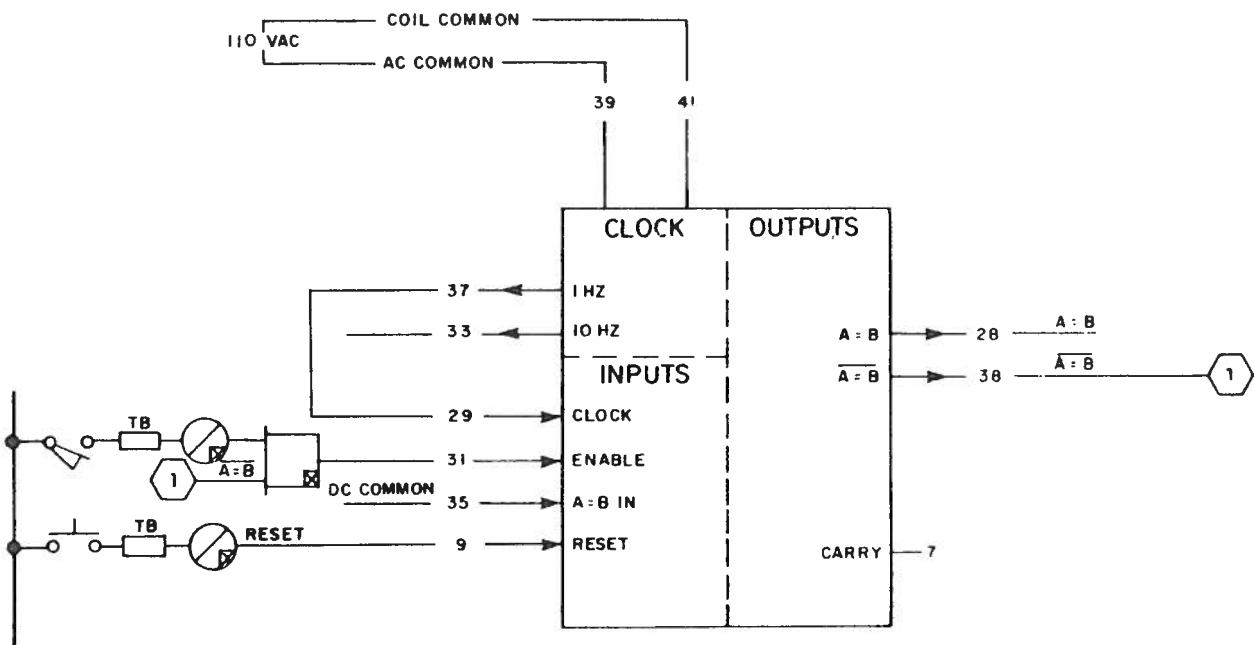

3-DIGIT COUNTER/TIMER

APPLICATION EXAMPLES

3. Digital Timer cascade operation (0 to 999999 Sec)

Any number of modules can be cascaded. The module with the least significant digits must be clocked by 1 Hz or 10 Hz (timer operation) and its A = B input must be tied to pin 1. Its A = B output must be tied to the A = B input of the next module and its CARRY must be tied to the CLOCK of the next module.

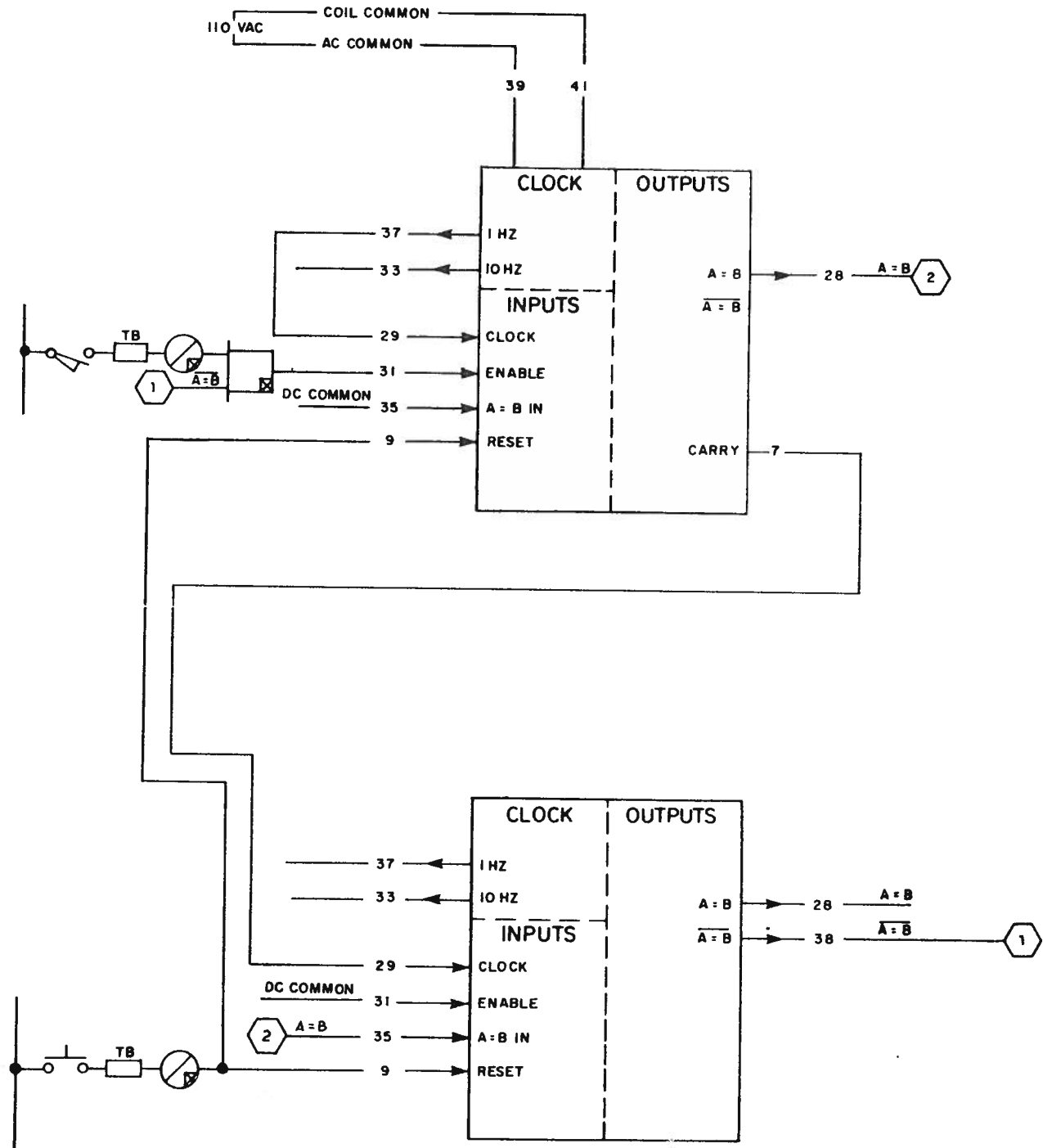

3-DIGIT COUNTER/TIMER

APPLICATION EXAMPLES

4. Digital Counter (0 to 999)

See Application Example 3 for cascading digital counters. Counter will increment each time limit switch is closed and opened. When thumbwheel setting is reached, counter will stop.

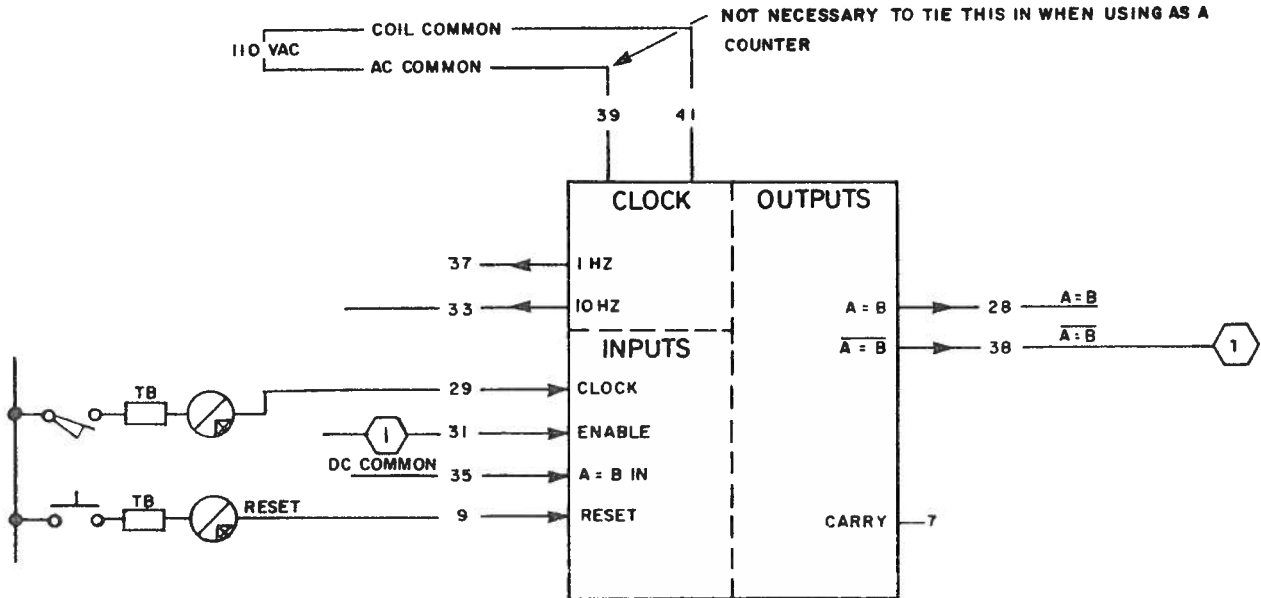

5. Module configuration of NL-361TR with readouts and thumbwheels on module

6. Module configuration of NL-361TRB with readouts, thumbwheels, and buffer module

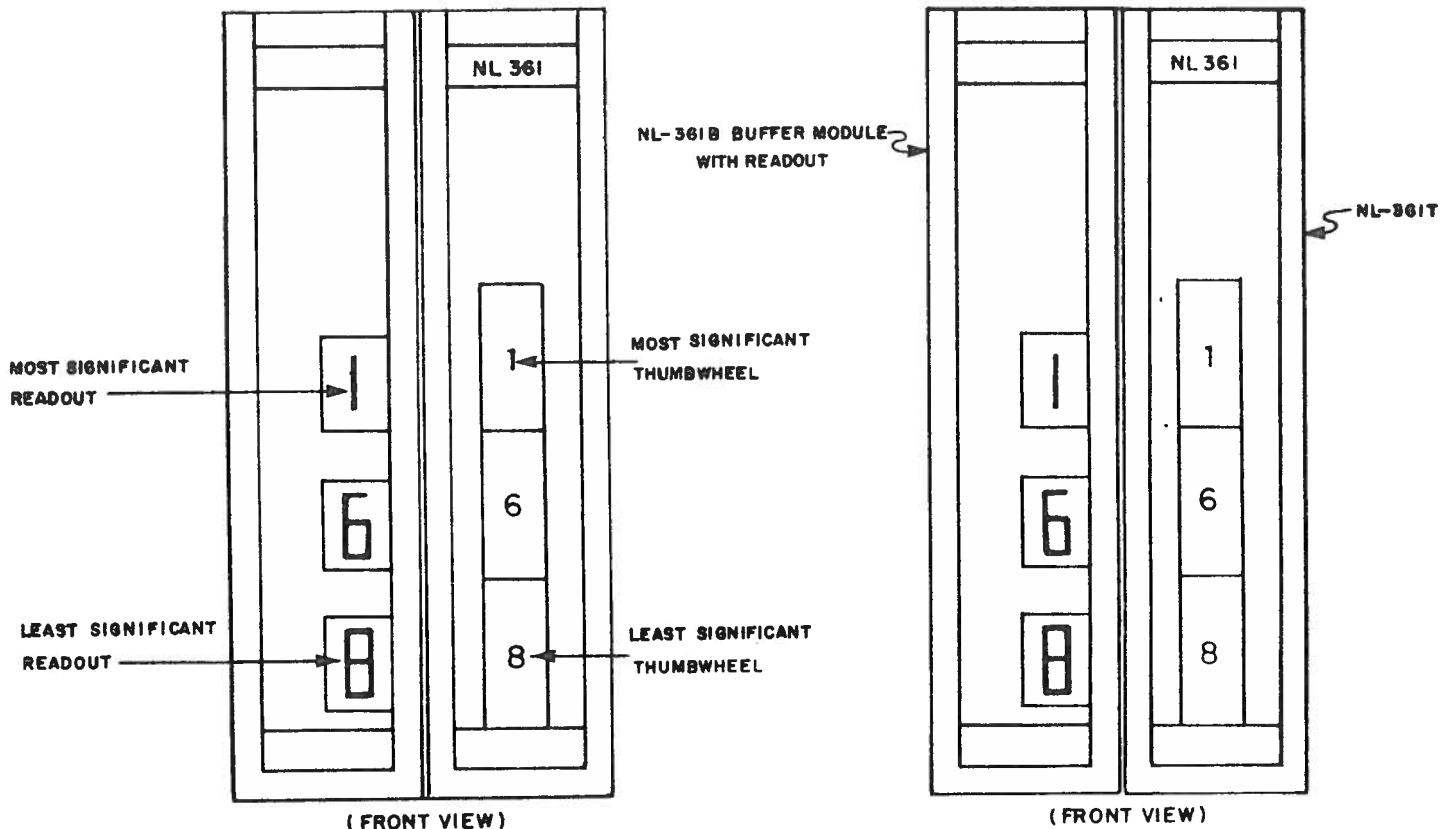

NOTE: READOUT OR BUFFER MODULE REQUIRES MODULE SLOT



3-DIGIT COUNTER/TIMER

APPLICATION EXAMPLES

7. NL-361B buffer module used with NL-361 counter/timer for remote readouts and/or remote 3-digit thumbwheel comparators

PIN CONFIGURATION:

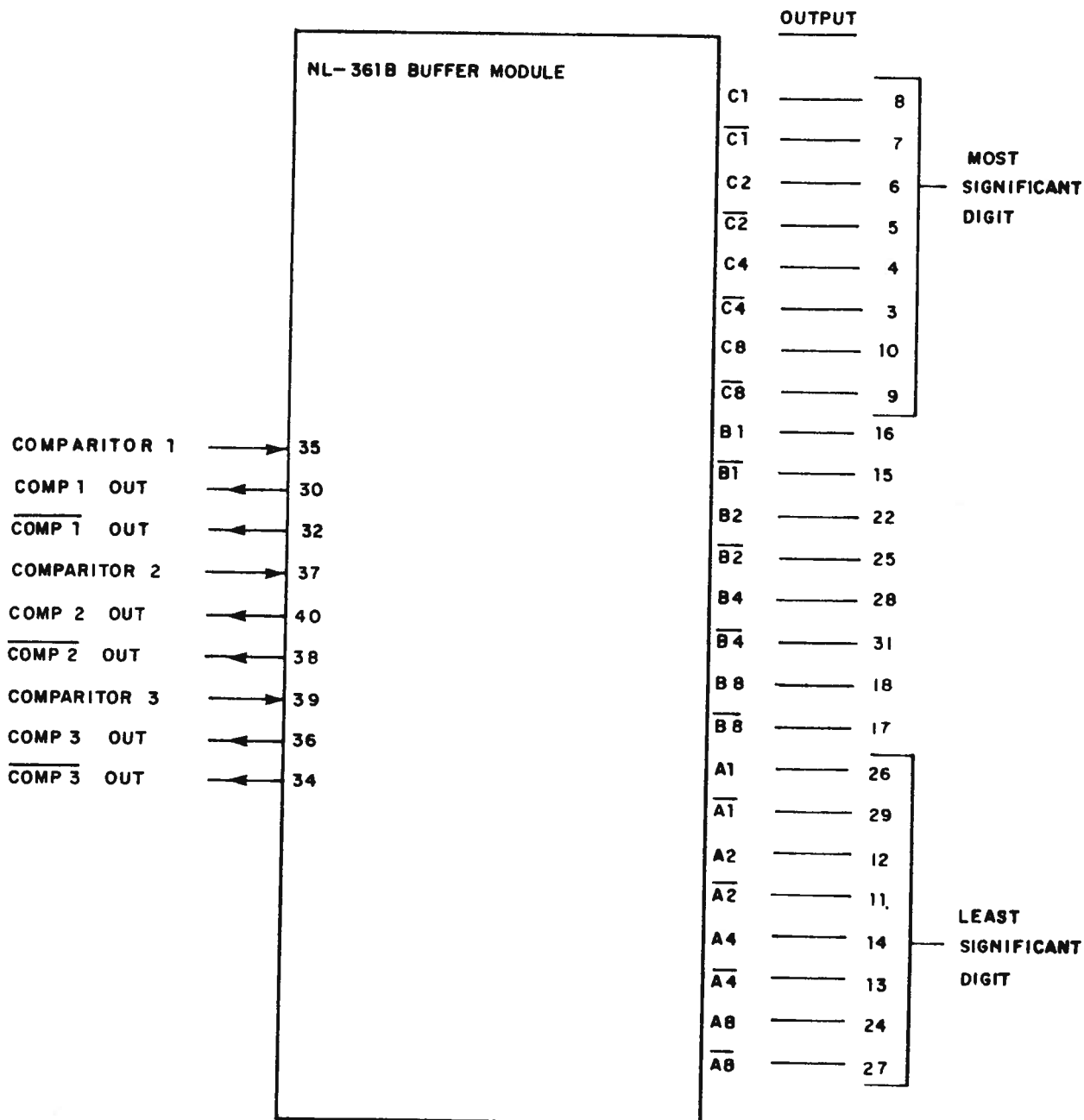

3-DIGIT COUNTER/TIMER

APPLICATION EXAMPLES

8. Buffer module used with remote readout

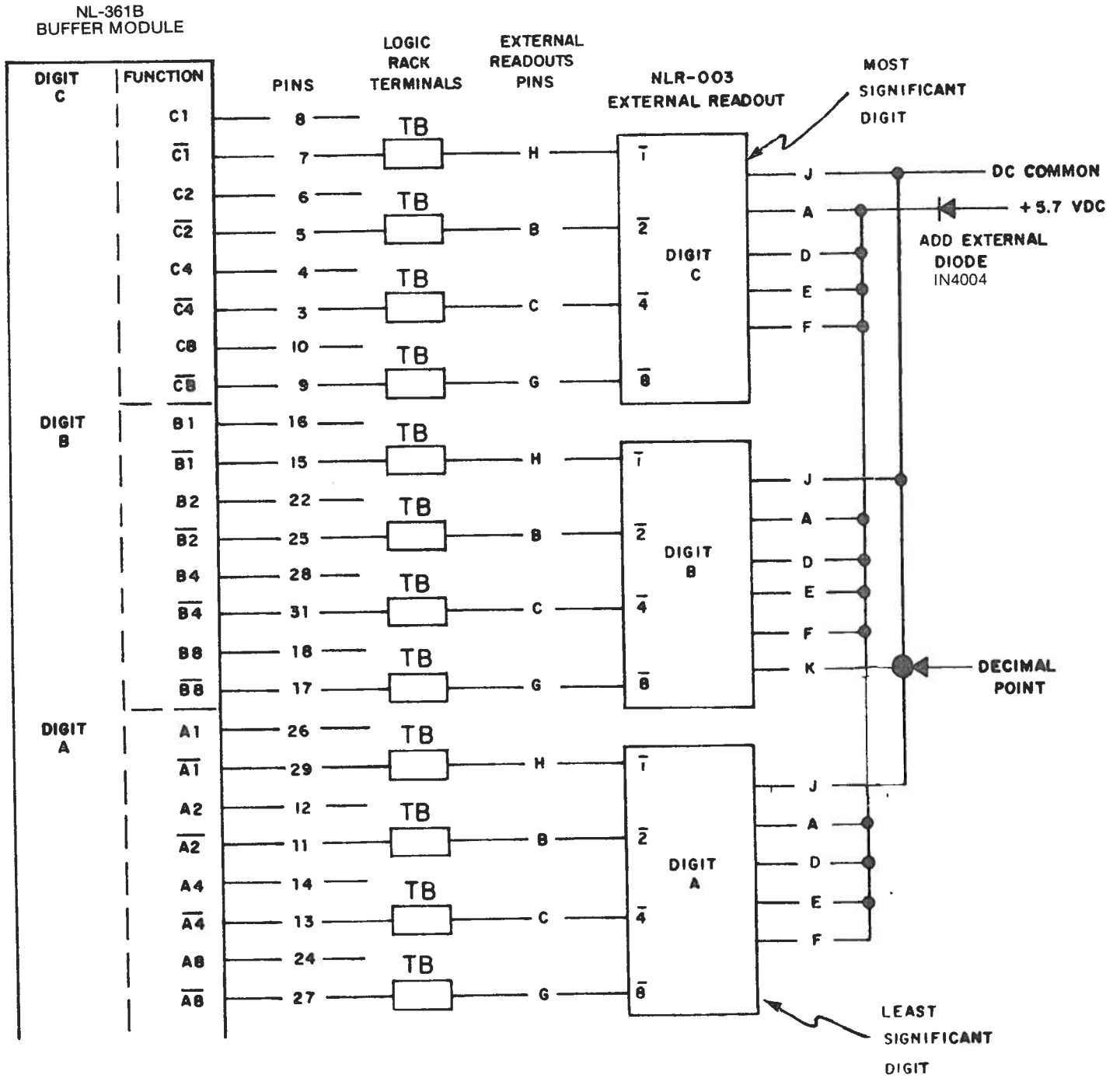

3-DIGIT COUNTER/TIMER

APPLICATION EXAMPLES

9. Buffer module used with external thumbwheel comparators

USED IN APPLICATIONS WHERE SEVERAL SET POINTS ARE REQUIRED. THIS EXAMPLE SHOWS 2 SET POINTS WITH COMPARATOR OUTPUTS TIED THRU A FILTER ON THE NL-361B BUFFER IN TO THE NUMA-LOGIC SYSTEM

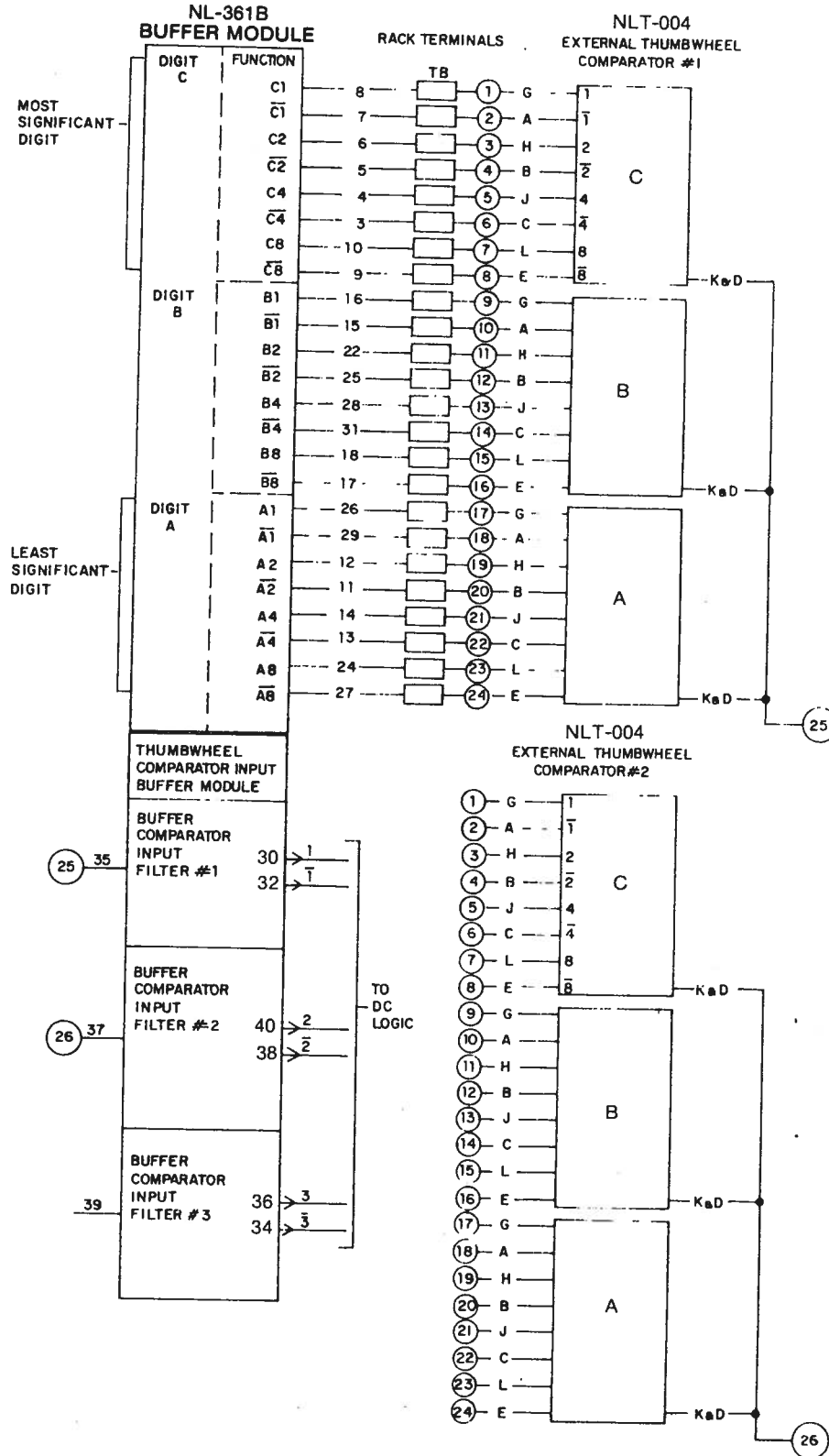

3-DIGIT COUNTER/TIMER

3-digit Thumbwheel Comparator NLT-004

Used in applications where several set points are required.

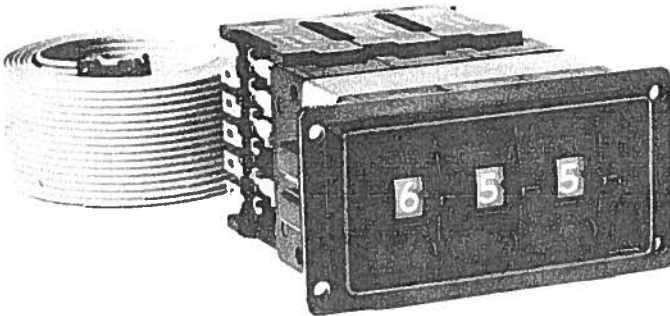

DIMENSIONS in Inches

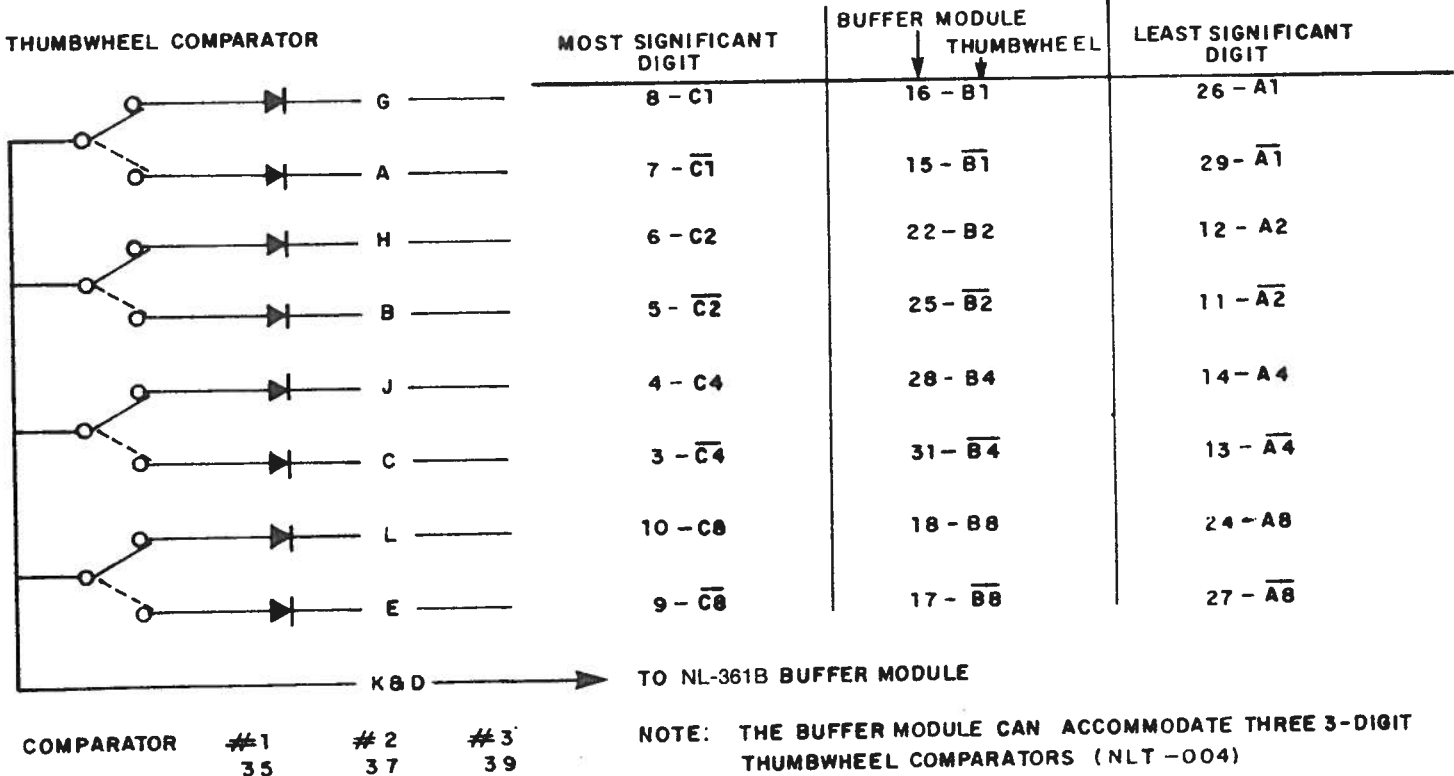
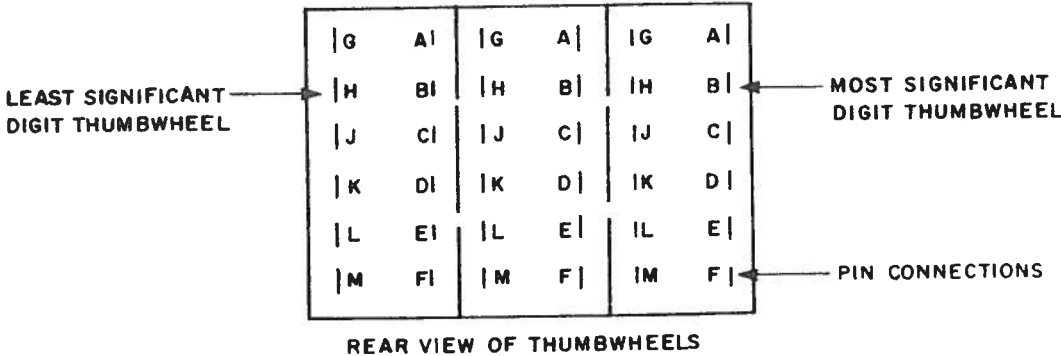
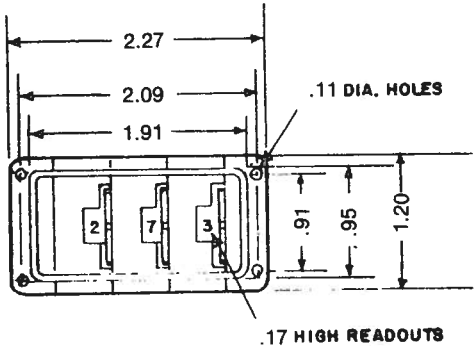

3-DIGIT COUNTER/TIMER

Remote Thumbwheels NLT-003

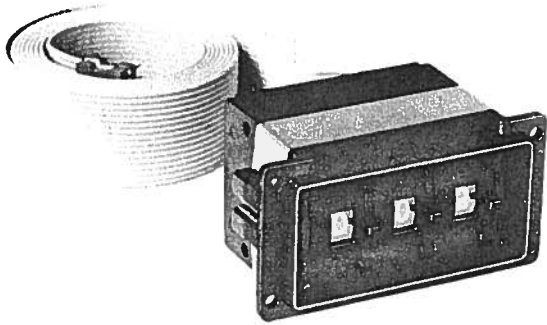

DIMENSIONS in inches

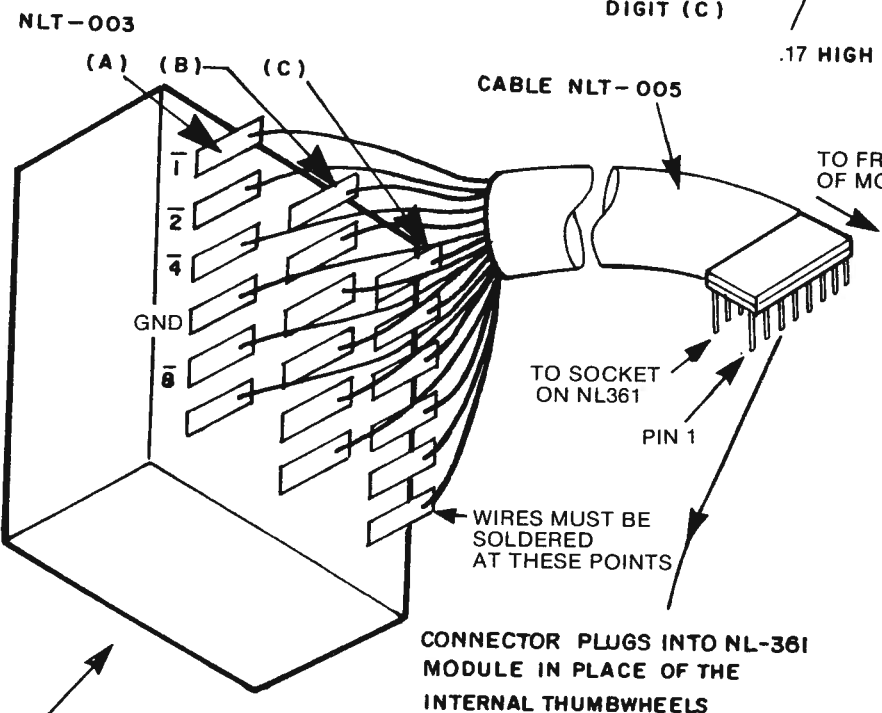
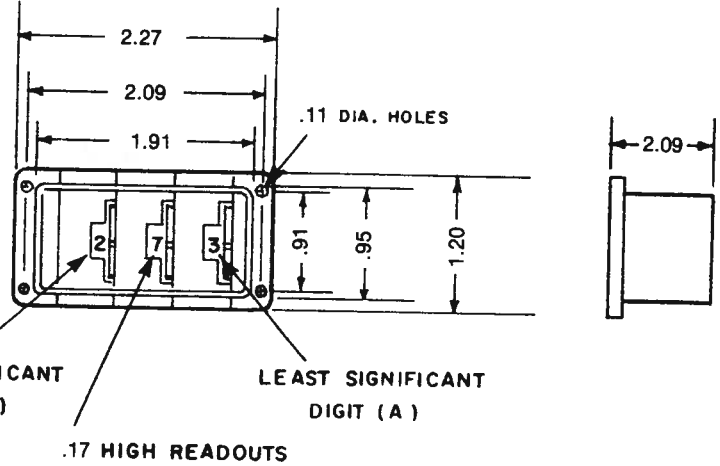

CONNECTIONS

FUNCTION	WIRE NO.	
C 1	16	8
C 8	15	9
C 2	14	7
B 1	13	10
C 4	12	6
B 2	11	11
GND	10	5
GND	9	12
GND	8	4
GND	7	13
A 2	6	3
B 4	5	14
A 4	4	2
B 8	3	15
A 8	2	1
A 1	1	16

RED STRIPE
 C = PREFIX MSD
 B = PREFIX NSD
 TOP VIEW OF CONNECTOR
 A = PREFIX LSD

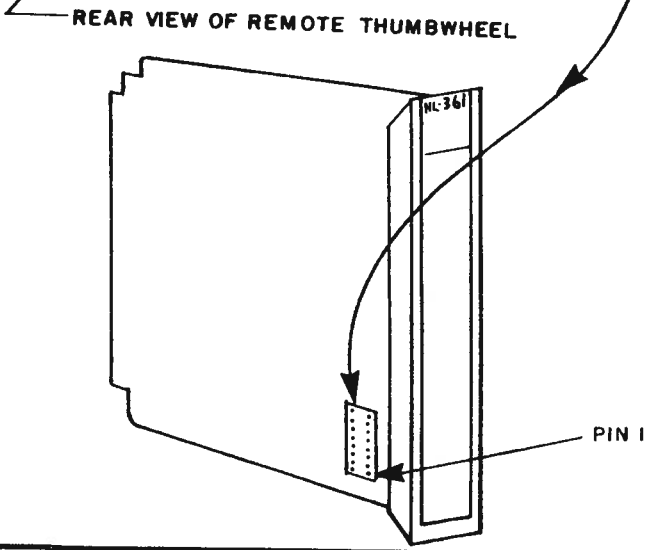

3-DIGIT COUNTER/TIMER

Remote Readout NLR-003

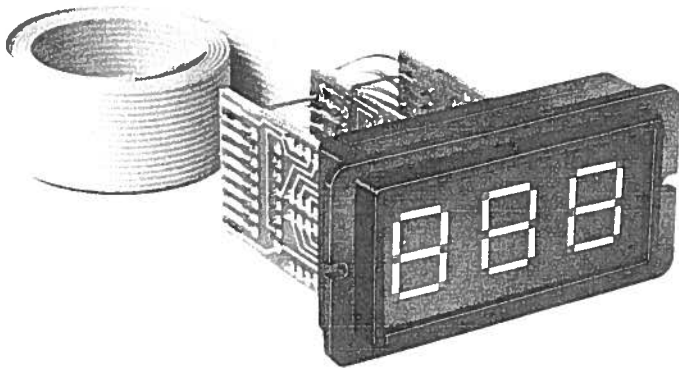

DIMENSIONS In Inches

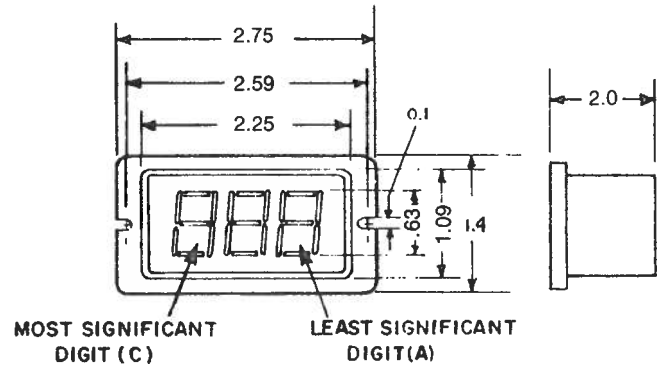

Temperature range	0° to 65°C
Supply voltage	+5 ± 0.25 VDC
Supply current	254 mA readout 762 mA all segments illuminated 782 mA all segments and decimal point illuminated
When decimal is required	Jumper pins K and J of digit B on the NLR-003



